

DYNAMICS OF MACHINERY

TUTORIAL - 1 (01/09/06)

Do not use any book as far as possible.

Time yourself and indicate the time required for solving each of the problems.

The solutions must be submitted on full scale paper, if you wish to get them corrected.

Only the first few who submit will have their papers checked.

(100 Marks - 180 mins)

Units Covered : Free Undamped and Damped Vibrations

For Private Circulation Only

Q1a : Prove that for finding the natural frequency of a spring mass system, the mass of the spring can be taken into account by adding one third of its mass to the main mass.

(8 Marks)

Q1b : Find the natural frequency of the system shown in Fig. I. Neglect the effect of weight of pulleys.

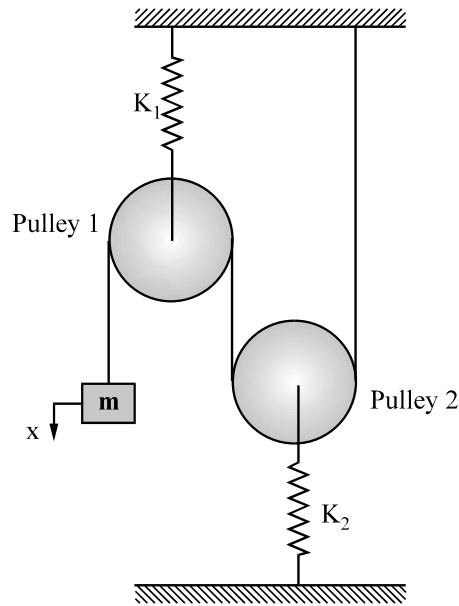

Fig. I

(8 Marks)

Q2a : Find the natural frequency of system shown in Fig II. If m , K_1 , K_2 , L are fixed, find the value of 'b' for which the system will not vibrate.

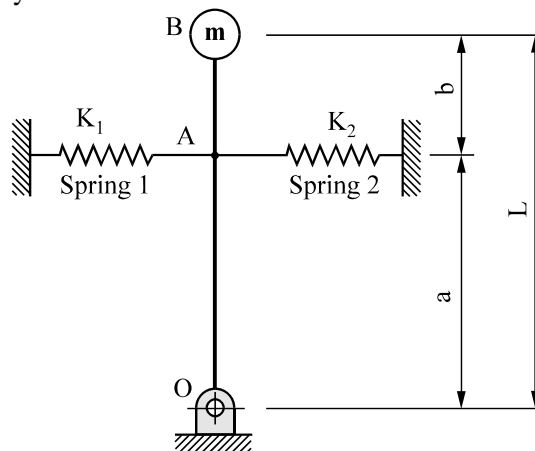

Fig. II

(8 Marks)

Q2b : The mass 'm' is hanging from a chord attached to the circular homogeneous disc of mass 'M' and radius 'R' as shown in Fig III. The disc is restrained from rotating by a spring attached at radius 'r' from the centre. If the mass is displaced downwards from rest position, determine the frequency of oscillations.

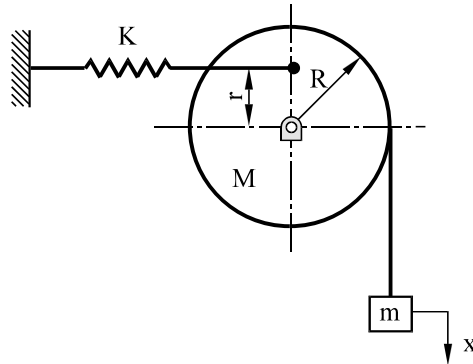

Fig. III

(8 Marks)

Q3a : Write short notes on (any three):

- i). Natural frequency and resonance
- ii). Degrees of freedom
- iii). Elements constituting Vibrations.
- iv). Mathematical Modeling of a vibrating body

(6 Marks)

Q3b : A circular plate with a hole is as shown in Fig. IV. Determine the time period of oscillations of the disk and the length of a simple pendulum which has the same period.

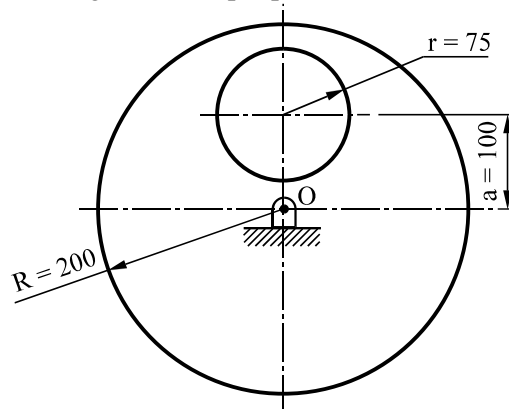

Fig. IV

(8 Marks)

Q3c : Determine the natural frequency of the system shown in Fig. V.

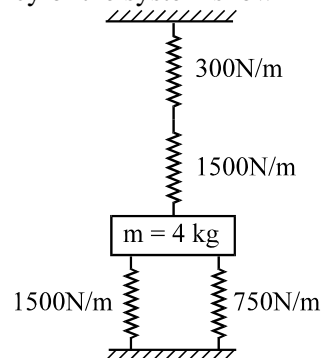

Fig. V

(4 Marks)

Q4a : A mass of 10 kg is supported by a vertical spring of 4000 N/m stiffness. There is a friction force of 15 N which always resists the vertical upward or downward displacement. The mass is released from a position in which the total extension of the spring is 105 mm. Determine the final extension of the spring in the position in which the system comes to rest.

(10 Marks)

Q4b : Derive a relation for determining the amount of decay per cycle in case of Coulomb Damping.

(6 Marks)

Q5a : A machine weighs 10 kg and is supported on springs and dashpots. The total stiffness of the springs is 15 N/mm and damping is 0.5 N sec/mm. The system is initially at rest and a velocity of 150 mm/s is imparted to the mass. Determine :

(i) The displacement and velocity of mass as a function of time.

(ii) The displacement and velocity after 0.3 sec.

(8 Marks)

Q5b : If the system shown in Fig. VI is dropped from an elevation 'h' to a hard rigid surface, what will be the resulting motion of the mass 'm'.

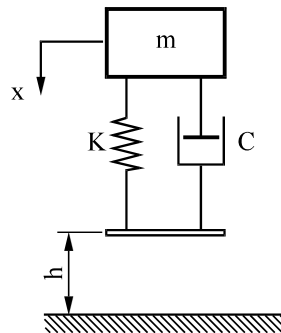

Fig. VI

(8 Marks)

6a : A mass of 3 kg is supported on a spring of 4500 N/m and has dashpot having damping coefficient of 3.5 N-sec/m. Find the damped natural frequency. Also find the logarithmic decrement and amplitude after 3 cycles, if the initial displacement is 5 mm.

(6 Marks)

6b : For the arrangement shown in Fig. VII, determine the differential equation of motion. Also determine the value of damping coefficient for the system to be critically damped.

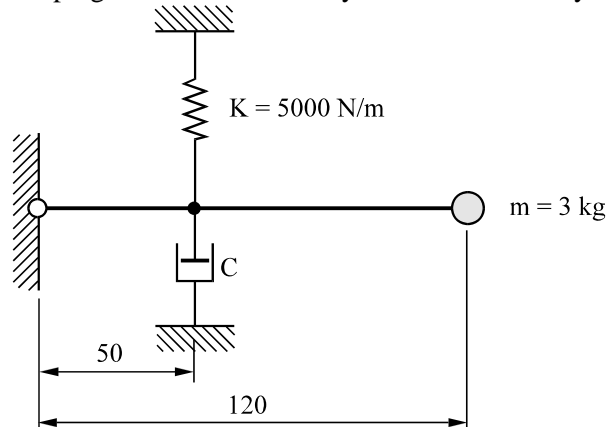

Fig. VII

(6 Marks)

6c : Derive a relation for logarithmic decrement. Explain the significance of this term.

(6 Marks)